

NORTHSTAR[★] CORE 4.35

Specifications

Length	4.35 m. / 14'3"
Beam	2 m. / 6'6"
Weight	180 kg. / 396 lbs
Tube Diameter	0.48 m. / 18.8"
Suggested Tube Pressure	0.18 bar / 2.6 psi
No. of Chambers	4
Maximum Persons	7
Minimum Power	30 HP
Maximum Power	50 HP
Recommended Power	40 HP
Shaft Length	L
Fuel Tank Capacity	-
Design Category	CE - Cat. C

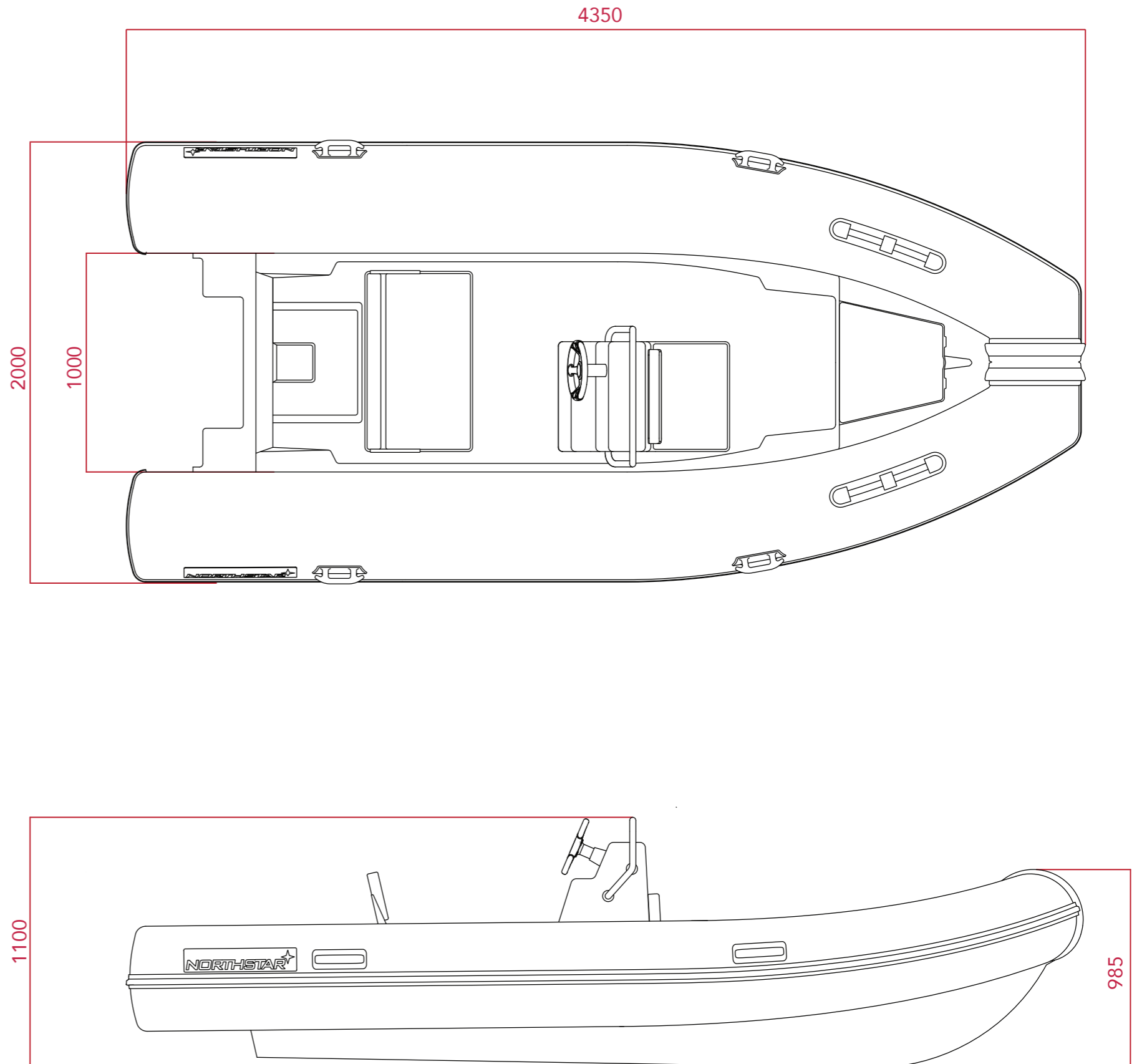

measurements in mm

NORTHSTAR[★] CORE 4.8

Specifications

Length	4.78 m.
Beam	1.97 m.
Maximum Payload	720 kg.
Empty Weight	270 kg.
Maximum Persons	8 pax
Tube Diameter	0.50 m.
Suggested Tube Pressure	0.18 bar / 2.6 psi
No. of Chambers	4
Maximum Power	85 HP
Recommended Power	60 HP
Shaft Length	L
Fuel Tank Capacity	-
Design Category	CE - Cat. C

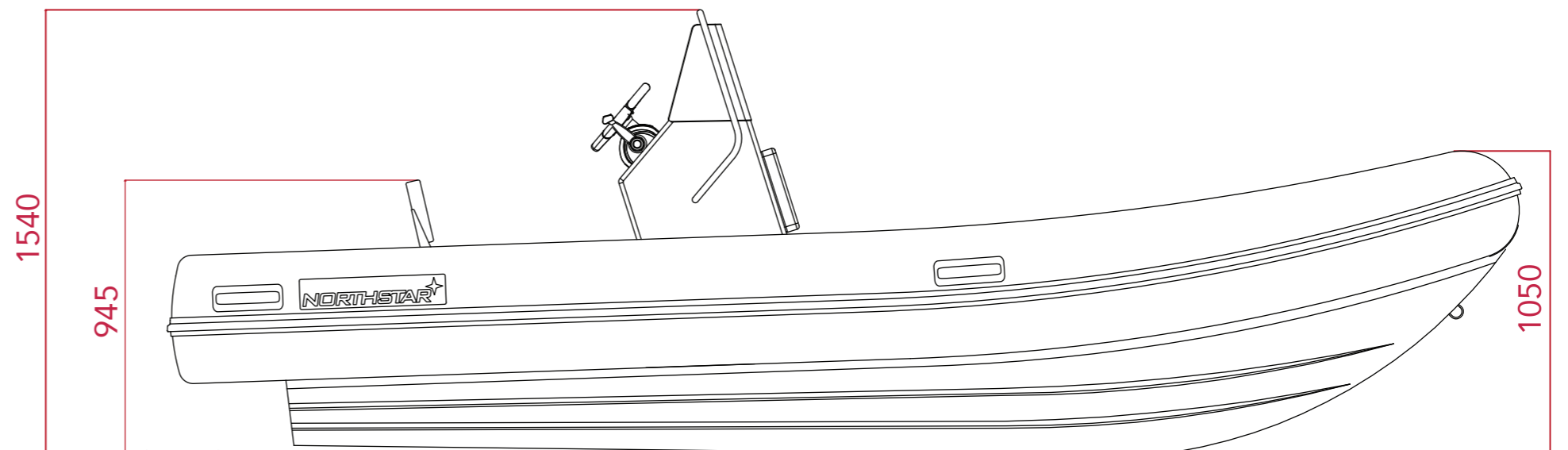
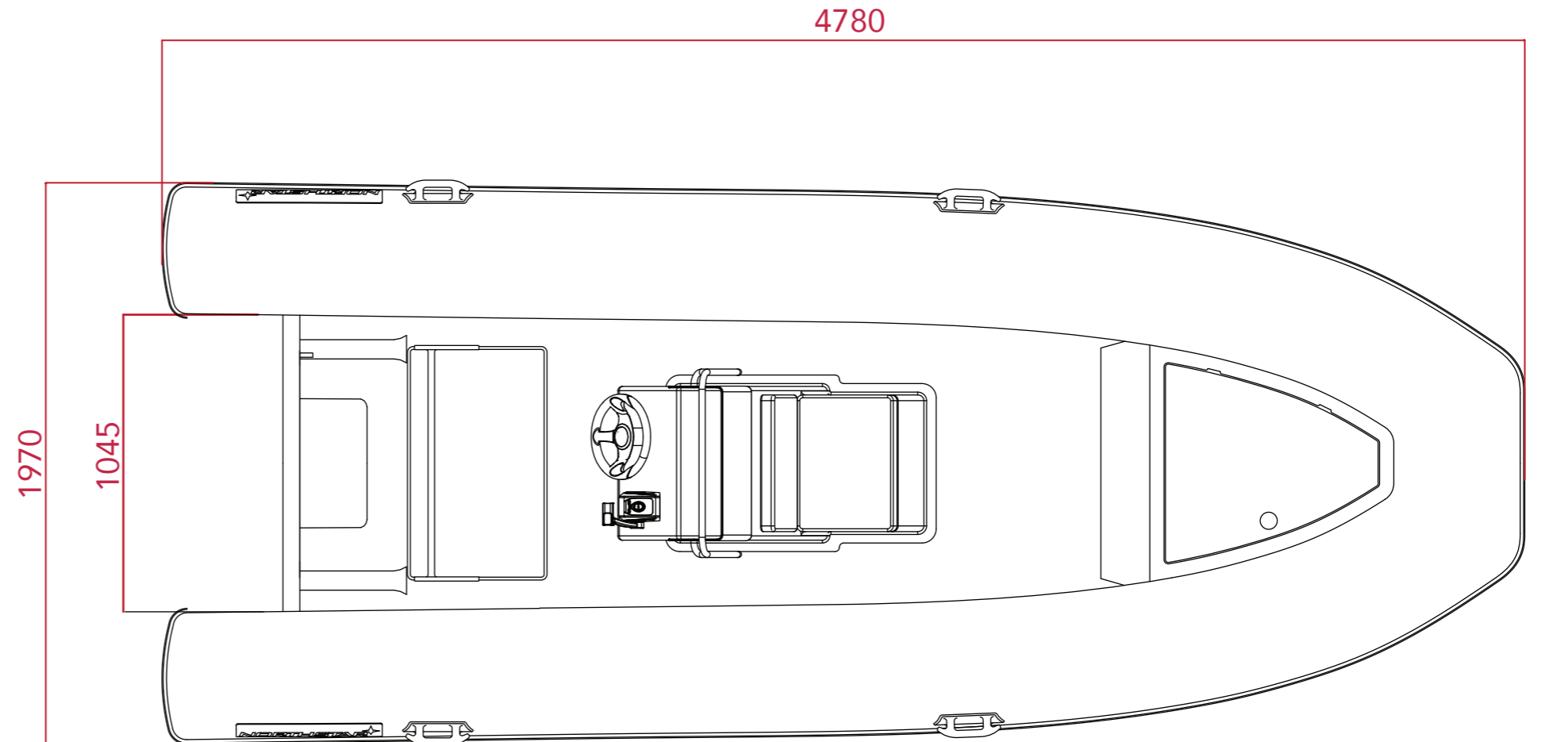

measurements in mm

NORTHSTAR[★] CORE 5.4

Specifications

Length	5.4 m.
Beam	2.2 m.
Maximum Payload	900 kg.
Empty Weight	420 kg.
Maximum Persons	10 pax
Tube Diameter	0.52 m.
Suggested Tube Pressure	0.18 bar / 2.6 psi
No. of Chambers	4
Maximum Power	115 HP
Recommended Power	90 HP
Shaft Length	L
Fuel Tank Capacity	-
Design Category	CE - Cat. C

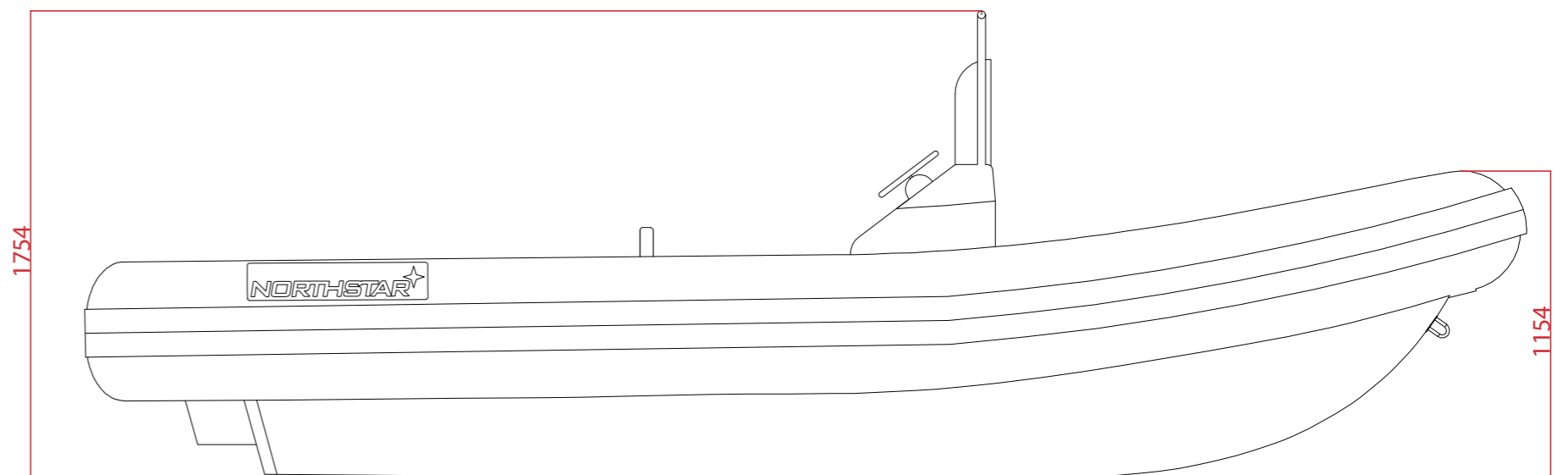
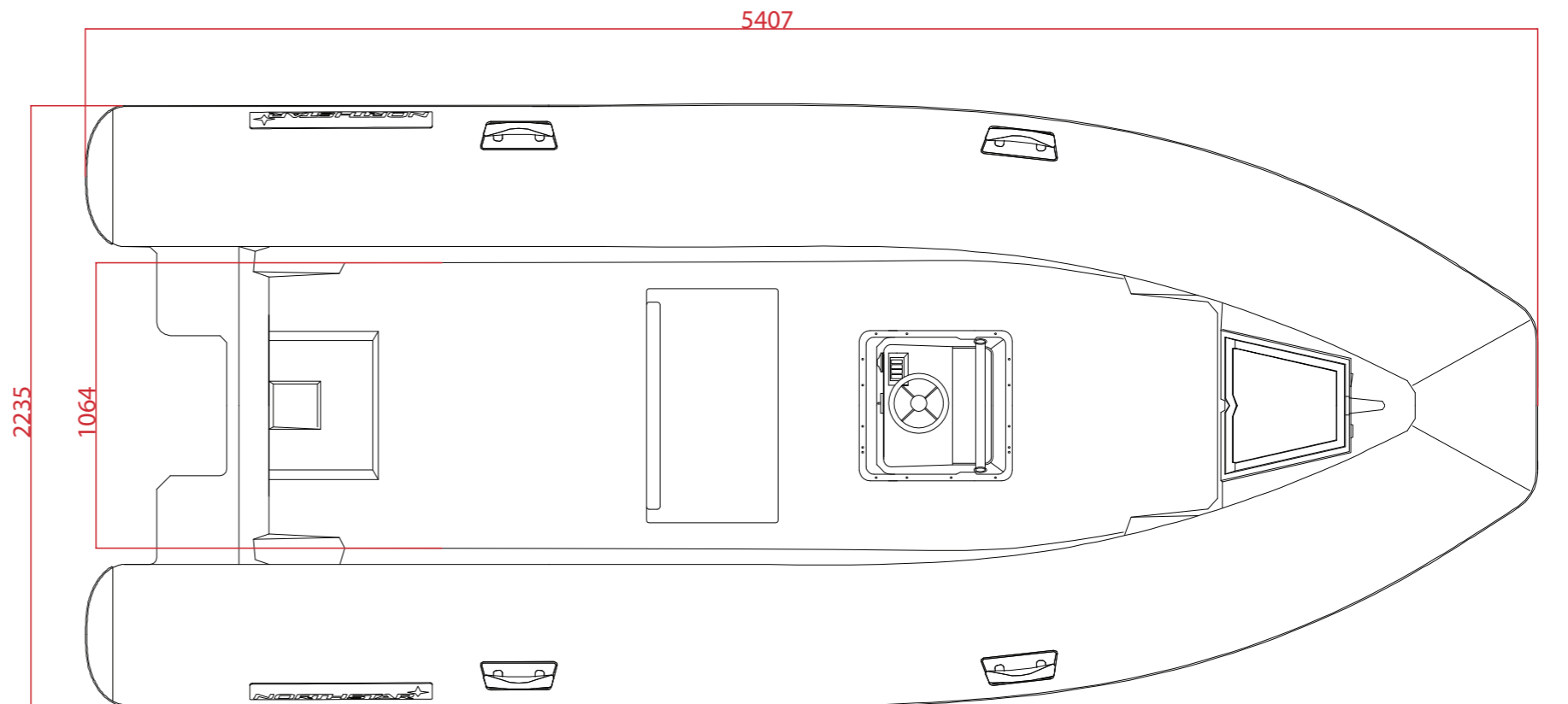

NORTHSTAR[★]

CORE 5.75

Specifications

Length	5.7 m.
Beam	2.4 m.
Maximum Payload	1020 kg.
Empty Weight	920 kg.
Maximum Persons	12 pax
Tube Diameter	0.53 m.
Suggested Tube Pressure	0.18 bar / 2.6 psi
No. of Chambers	5
Maximum Power	140 HP
Recommended Power	115 HP
Shaft Length	L
Fuel Tank Capacity	120 lt.
Design Category	CE - Cat. C

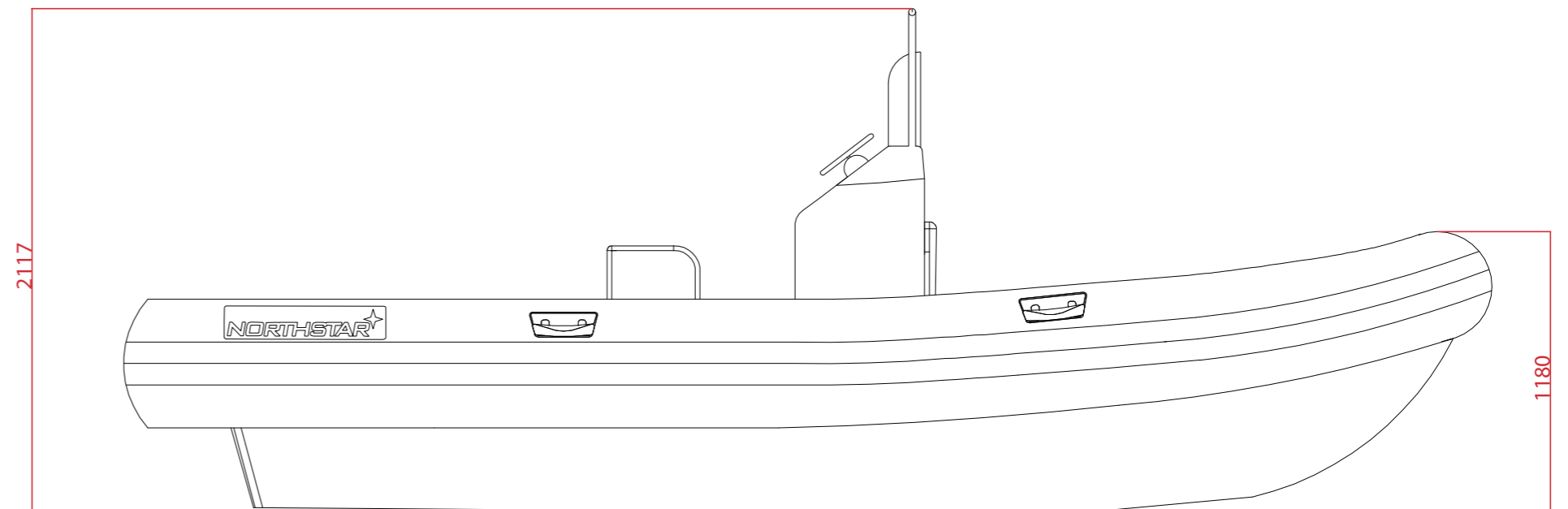
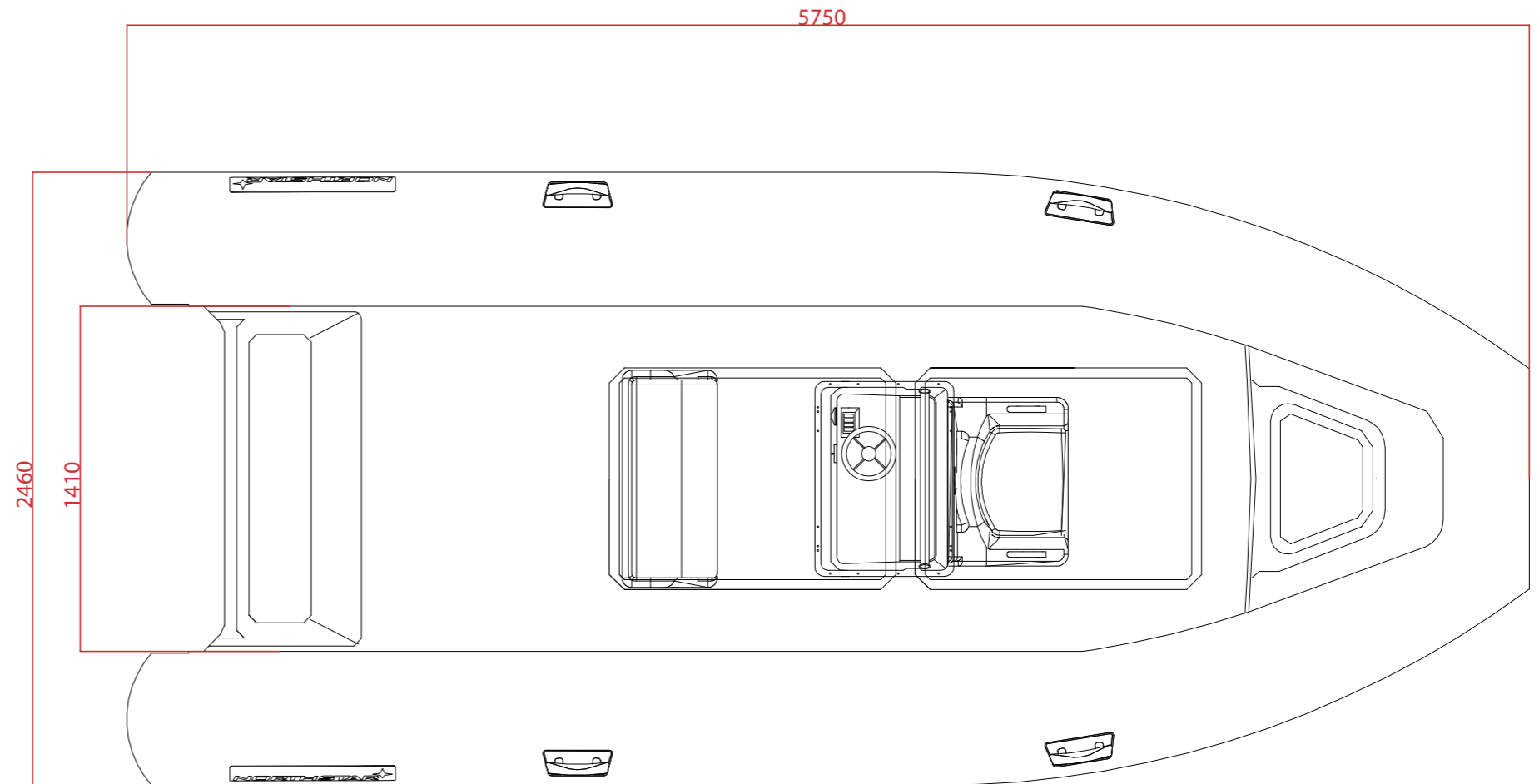

NORTHSTAR[★] CORE 6.4

Specifications

Length	6.4 m.
Beam	2.7 m.
Maximum Payload	1190 kg.
Empty Weight	935 kg.
Maximum Persons	13 pax
Tube Diameter	0.56 m.
Suggested Tube Pressure	0.18 bar / 2.6 psi
No. of Chambers	5
Maximum Power	200 HP
Recommended Power	175 HP
Shaft Length	XL / 2 L
Fuel Tank Capacity	170 lt.
Design Category	CE - Cat. B

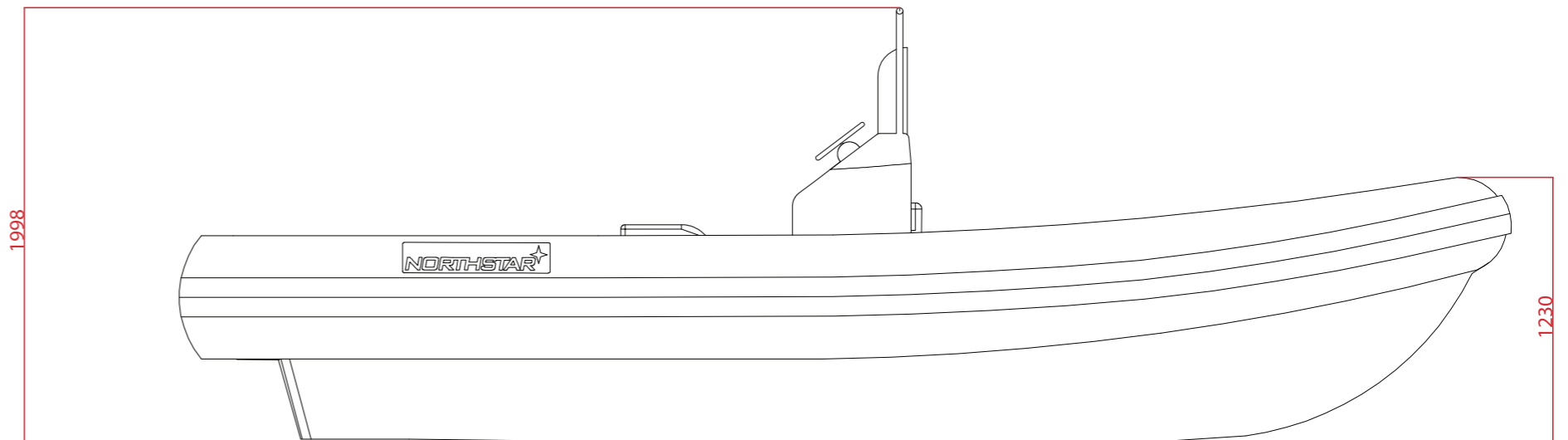
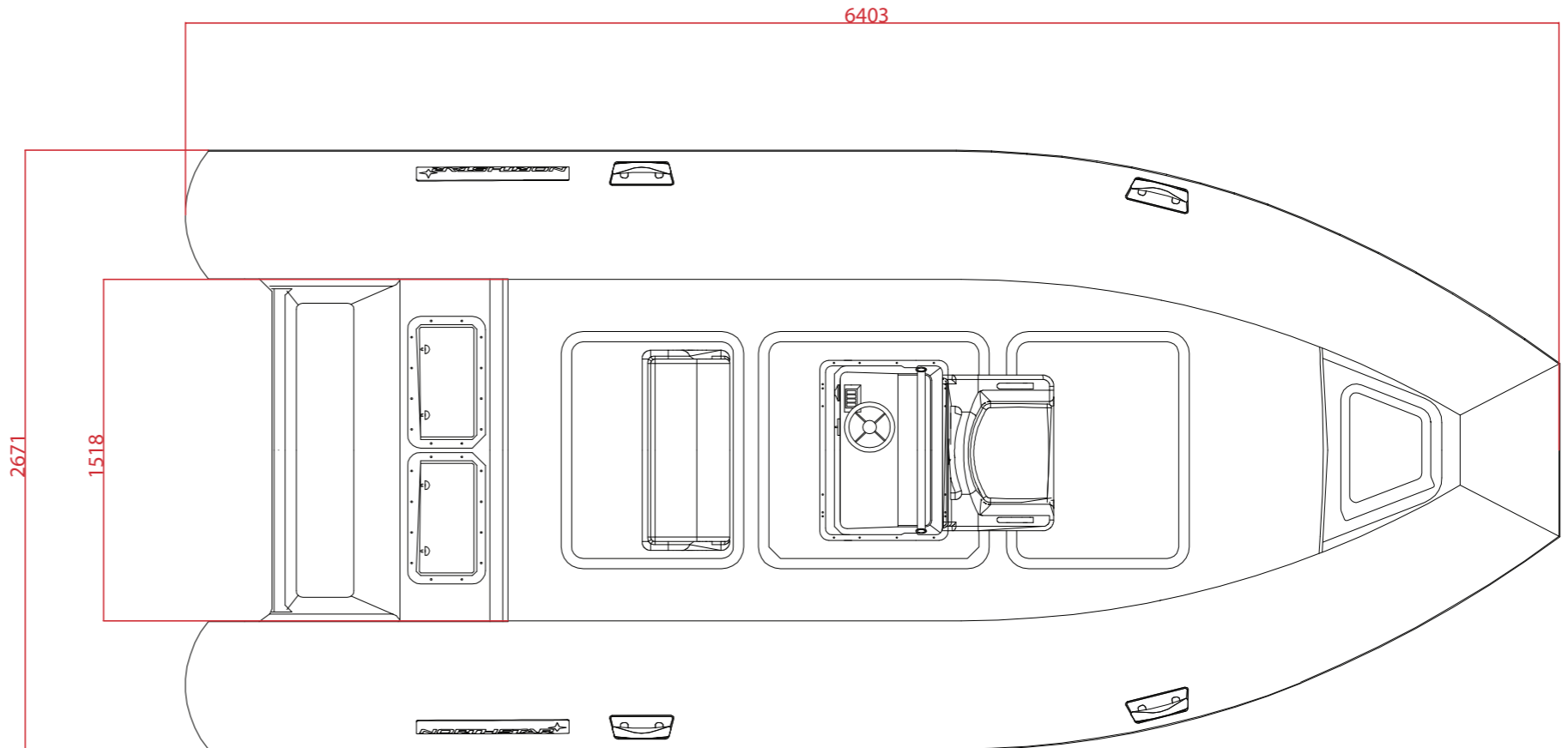

NORTHSTAR[★] CORE 7.2

Specifications

Length	7.3 m.
Beam	2.8 m.
Maximum Payload	1541 kg.
Empty Weight	- kg.
Maximum Persons	12 pax
Tube Diameter	0.58 m.
Suggested Tube Pressure	0.18 bar / 2.6 psi
No. of Chambers	8
Maximum Power	250 HP
Recommended Power	200 HP
Shaft Length	2 XL / XXL
Fuel Tank Capacity	400 lt
Design Category	CE - Cat. B

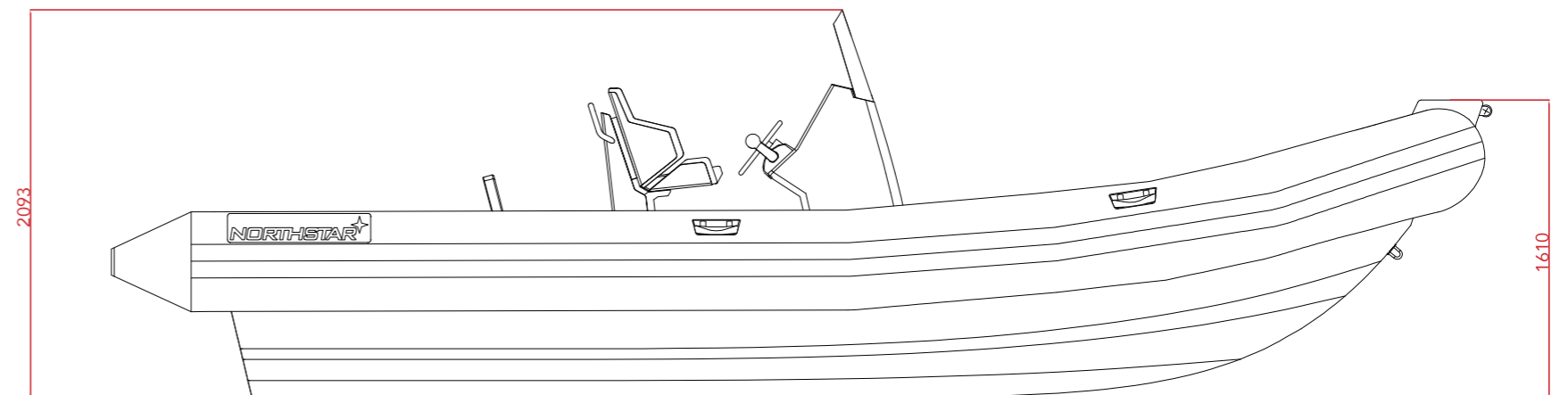
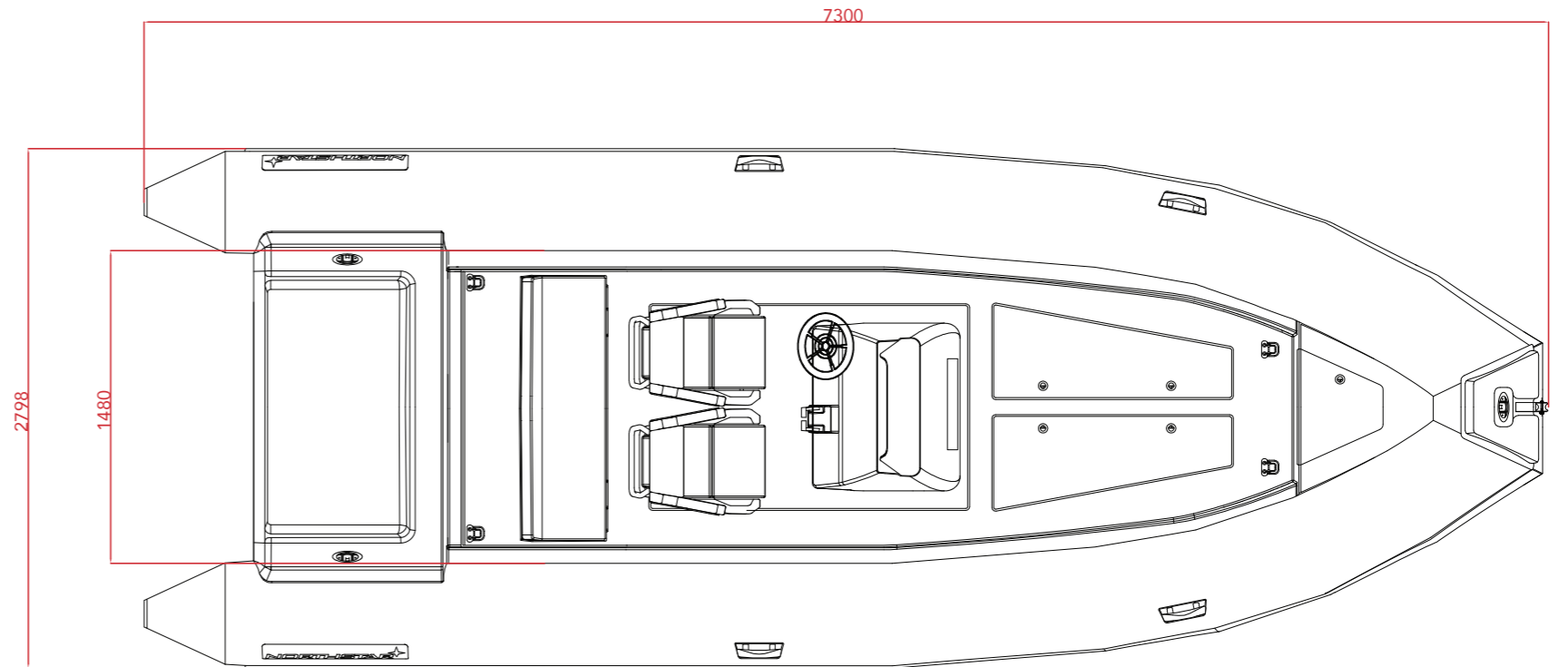

measurements in mm

NORTHSTAR[★] CORE 8

Specifications

Length	8 m. / 26'2"
Beam	2.8 m. / 9'2"
Max Payload	1800 kg. / 3970 lbs
Empty Weight	2200 kg. / 4850 lbs
Maximum Persons	18 pax
Tube Diameter	0.56 m. / 1'1"
Suggested Tube Pressure	0.18 bar / 2.6 psi
No. of Chambers	7
Maximum Power	350 HP
Recommended Power	300 HP
Shaft Length	XXL / 2 XL
Fuel Tank Capacity	450 lt. / 118 US Gal
Design Category	CE - Cat. B

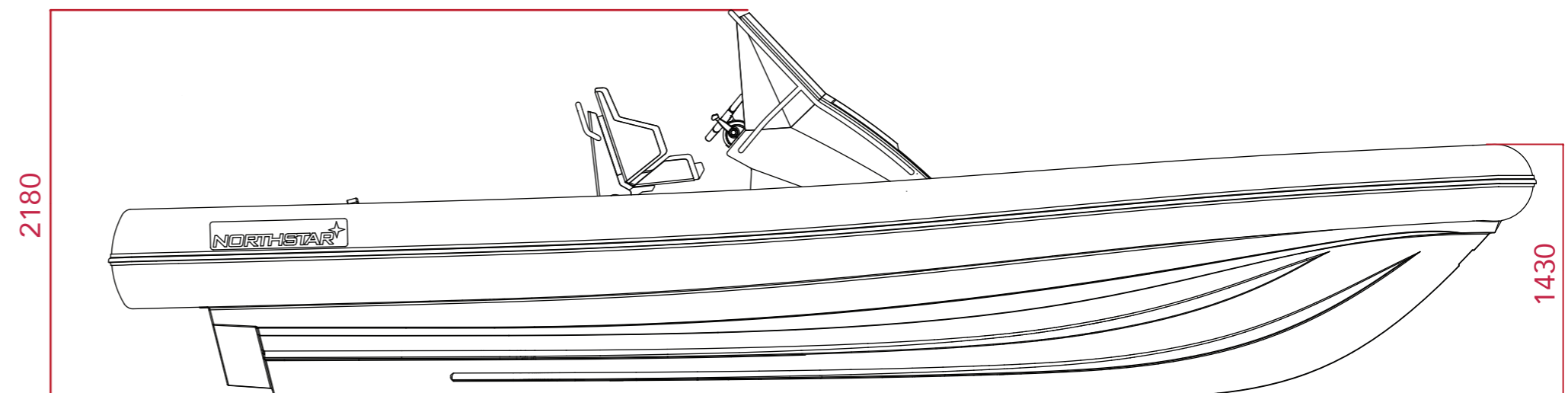
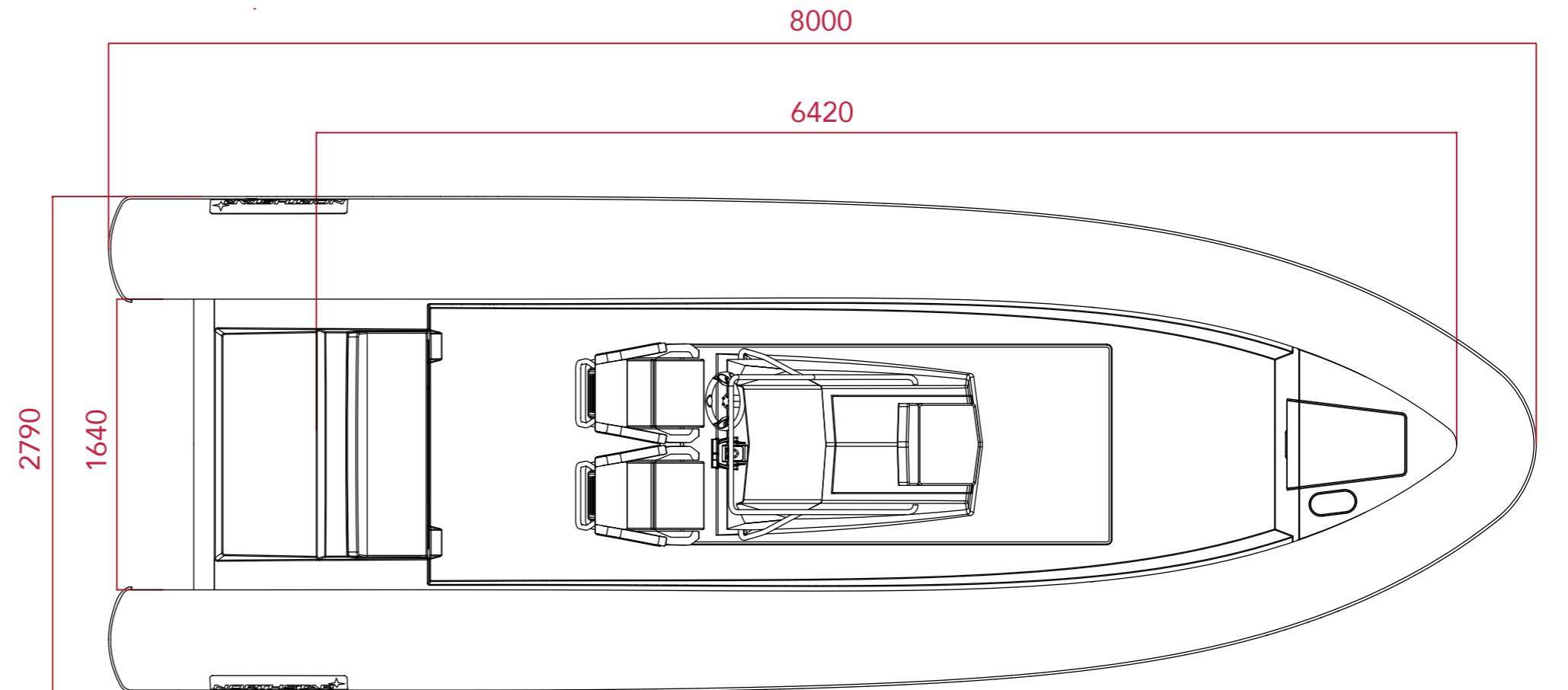

measurements in mm

NORTHSTAR[★] CORE 9.5

Specifications

Length	9.2 m.
Beam	3.05 m.
Maximum Payload	2025 kg.
Empty Weight	1540 kg.
Maximum Persons	20 pax
Tube Diameter	0.58 m.
Suggested Tube Pressure	0.18 bar / 2.6 psi
No. of Chambers	8
Maximum Power	600 HP
Recommended Power	500 HP
Shaft Length	2 XL / XXL
Fuel Tank Capacity	500 lt
Design Category	CE - Cat. B

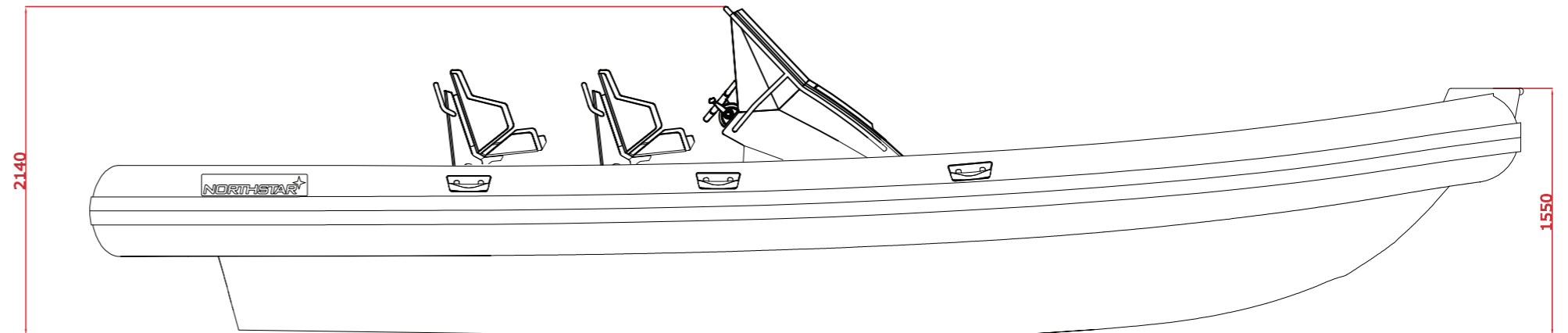
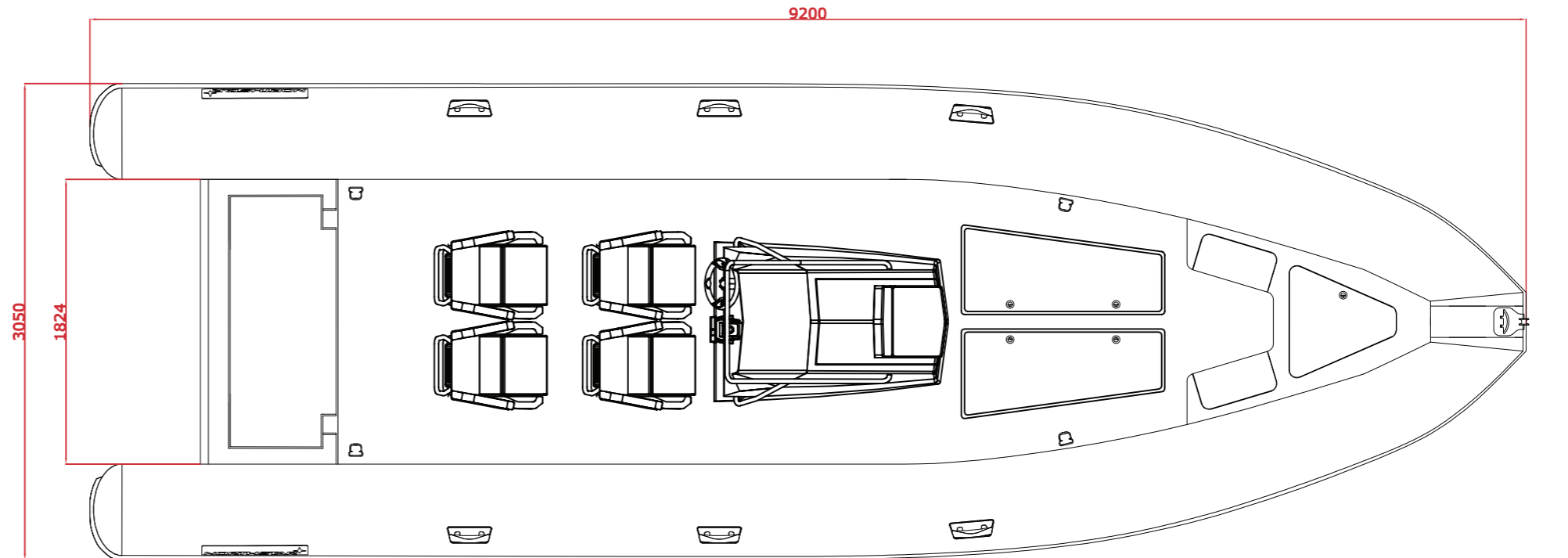

measurements in mm